



*Great sound
from Barcelona
since 1972*

www.amateaudio.com

User's manual Manual de usuario

FR-208R

Stacking frame for X208 / N208 on X21T / X21D / X218W3K / X218D / N218W / N218WP / X18T / X18D / N18W / N18WP / N18WPR / X218WF

Estructura para stacking de X208 / N208 sobre X21T / X21D / X218W3K / X218D / N218W / N218WP / X18T / X18D / N18W / N18WP / N18WPR / X218WF

October 2019

The FR-208R is an optional accessory for stacking the X208 or N208 on X218W3K, X218D, X21T, X21D, X18T, X18D, N18W, N18WP, N18WPR, N218W or N218WP subwoofers.

El FR-208R es un accesorio opcional para el stacking de la X208 o N208 sobre los subwoofers X218W3K, X218D, X21T, X21D, X18T, X18D, N18W, N18WP, N18WPR, N218W o N218WP.

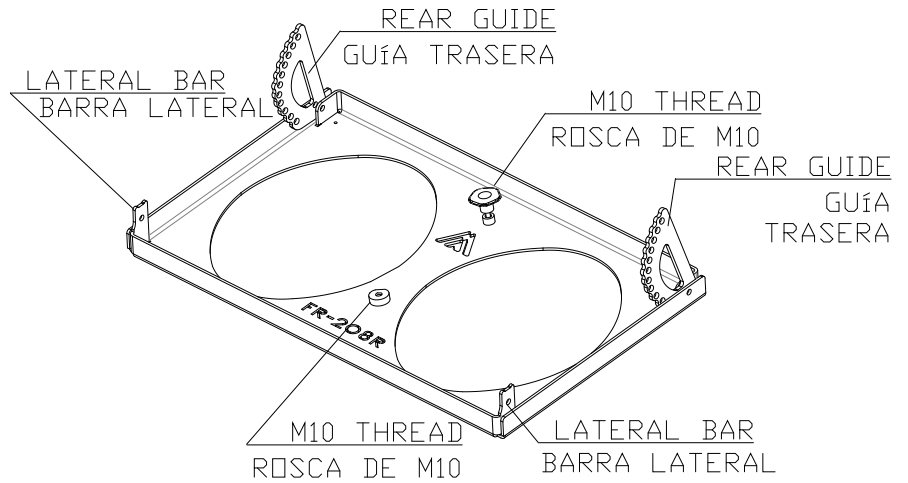

Stacking over X18T, X18D, N18W, N18WP, N18WPR subwoofers
Stacking sobre subwoofers X18T, X18D, N18W, N18WP, N18WPR

1- Place the M10-M20 adaptor (A) on the X18T, X18D, N18W, N18WPR or N18WP top socket (B).

Colocar el adaptador de M10 a M20 (A) dentro de la pletina superior del subwoofer X18T, X18D N18W, N18WPR o N18WP (B).

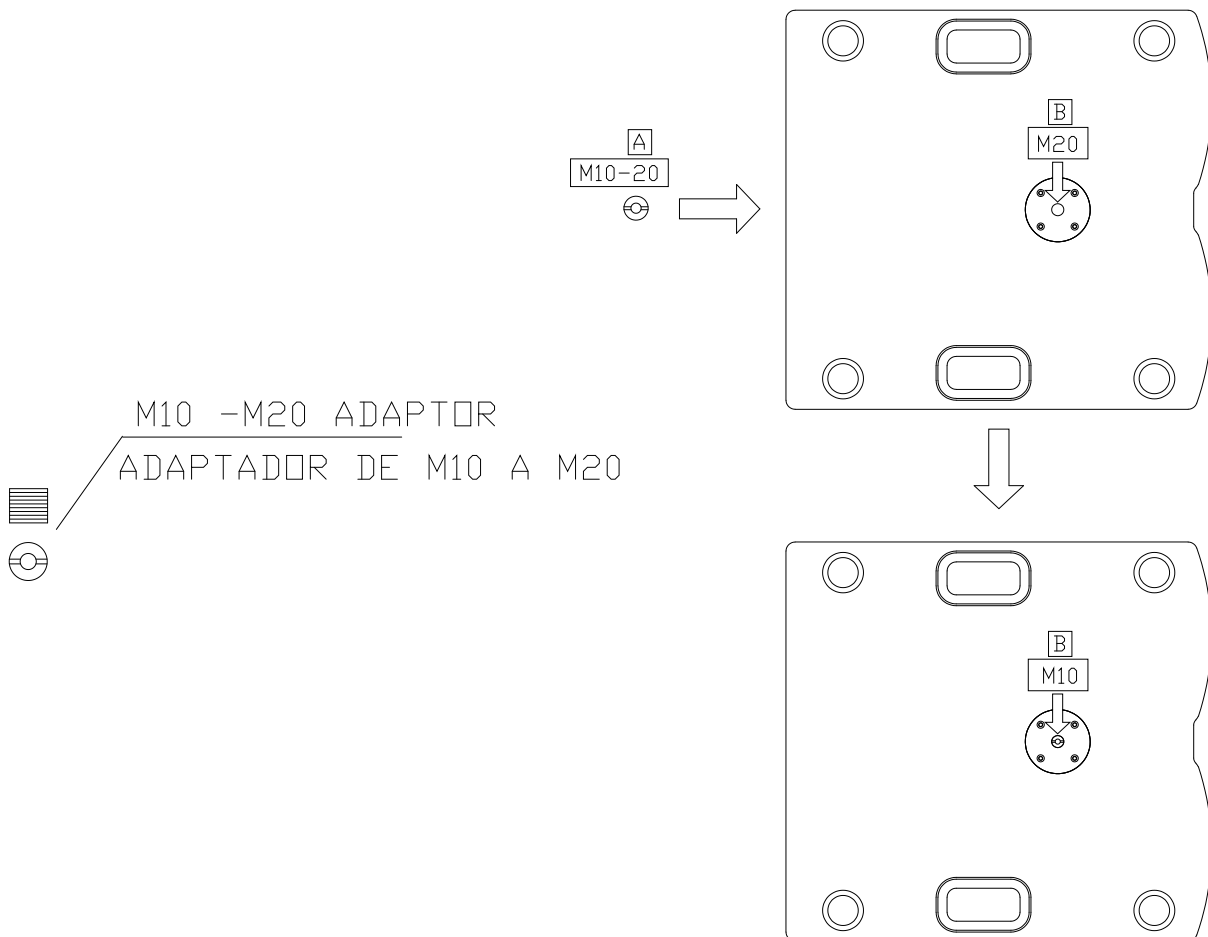

- 2- Place the FR-208R stacking frame on the X18T, X18D, N18W, N18WPR or N18WP subwoofer. The lateral bars must face upwards. The FR-208R M10 knob (A) must match the M10 thread (B) on X18T, X18D, N18W, N18WPR or N18WP top socket. Block all the structure using the FR-208R M10 knob (A).

Colocar la estructura de stacking FR-208R encima del subwoofer X18T, X18D N18W, N18WPR o N18WP. Las barras laterales deben estar mirando hacia arriba. El pomo de M10 del FR-208R (A) debe coincidir con la rosca de M10 de la base del X18T, X18D, N18W, N18WPR o N18WP (B). Asegure toda la estructura bloqueando el pomo de M10 del FR-208R (A).

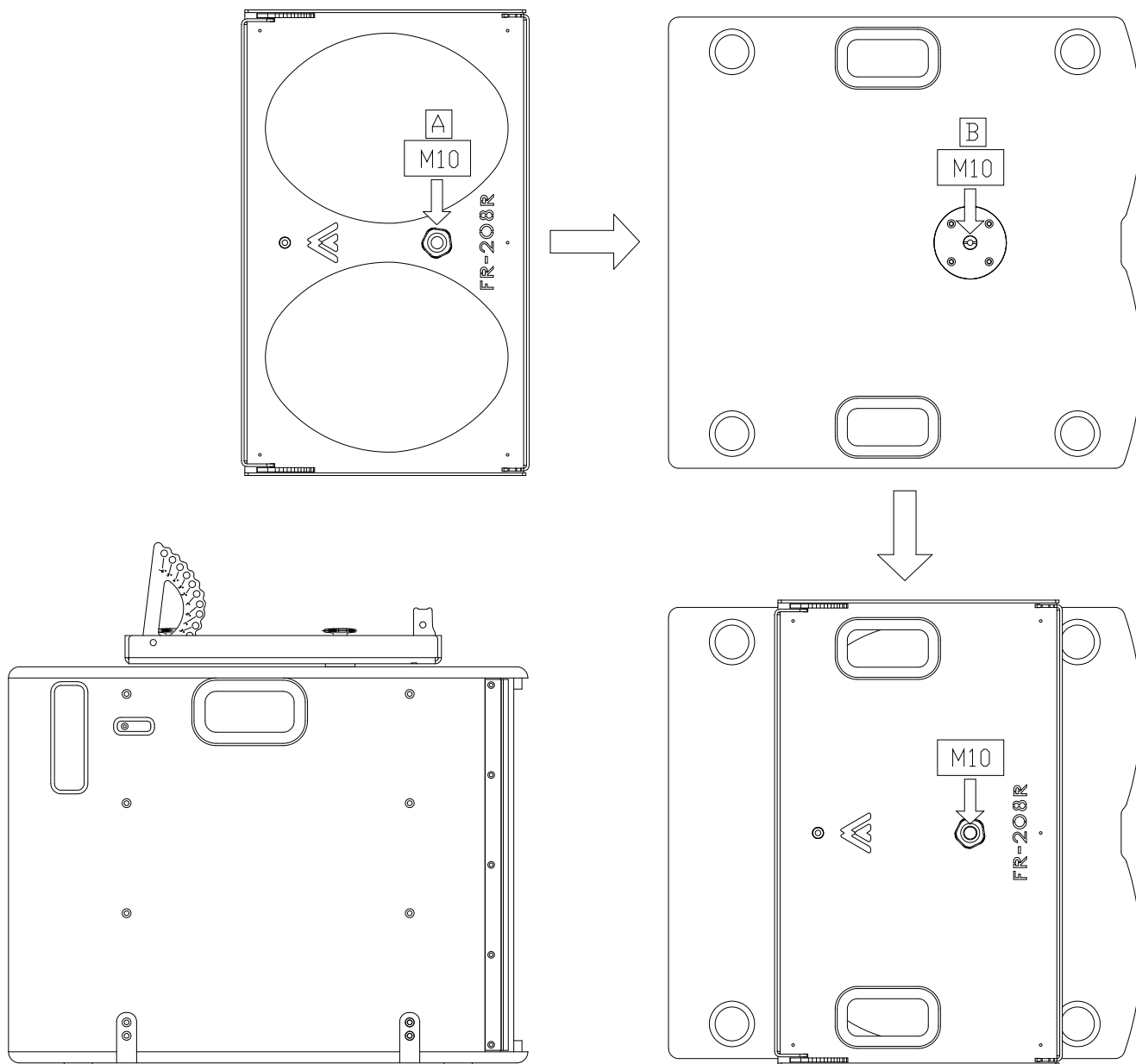

- 3- Set the first X208 or N208 cabinet on the FR-208R stacking frame. Use the rear guides to tilt the cabinet. The cabinet can be tilted from 6 degrees (upwards) to 6 degrees (downwards).

Colocar la primera caja X208 o N208 encima de la estructura de stacking FR-208R y graduar según las necesidades. La caja puede ser graduada desde 6° (hacia arriba) hasta 6° (hacia abajo).

Convex stacking / Rear guide +6°
Stacking convexo / Guía trasera +6°

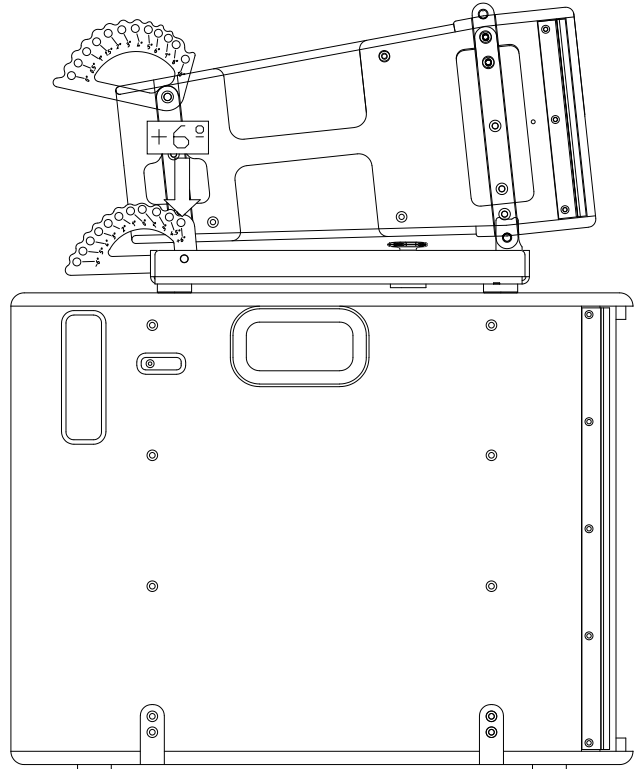
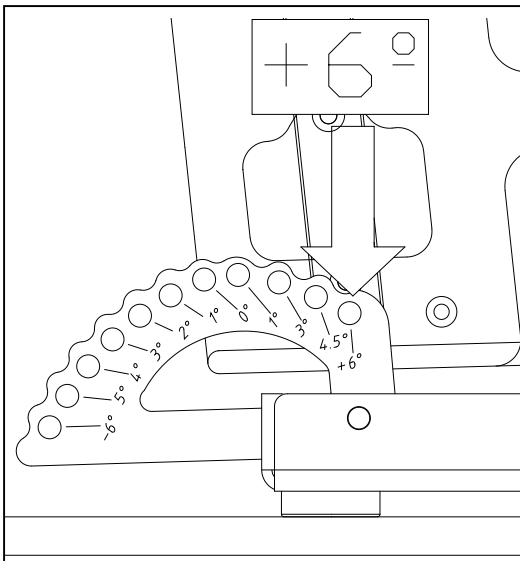

Flat stacking / Rear guide 0°
Stacking plano / Guía trasera 0°

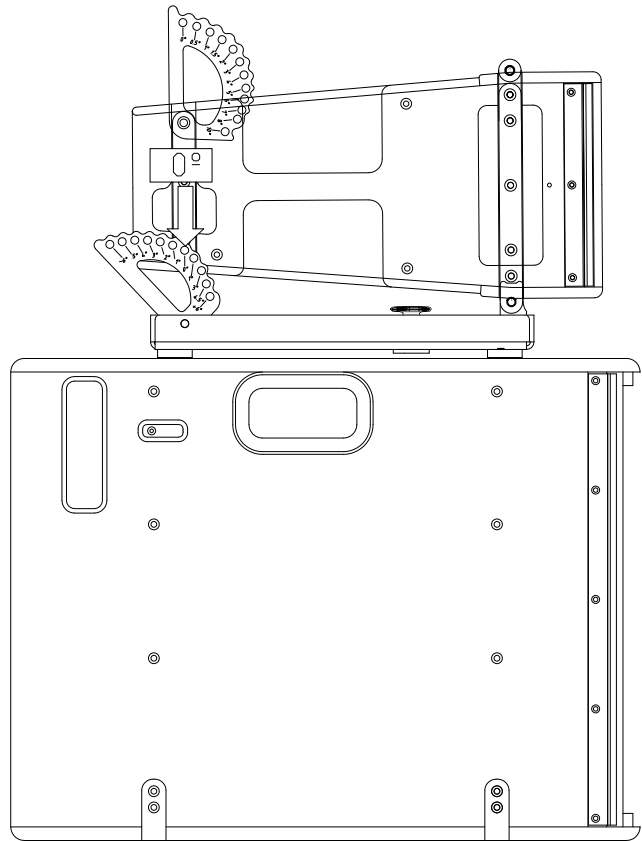
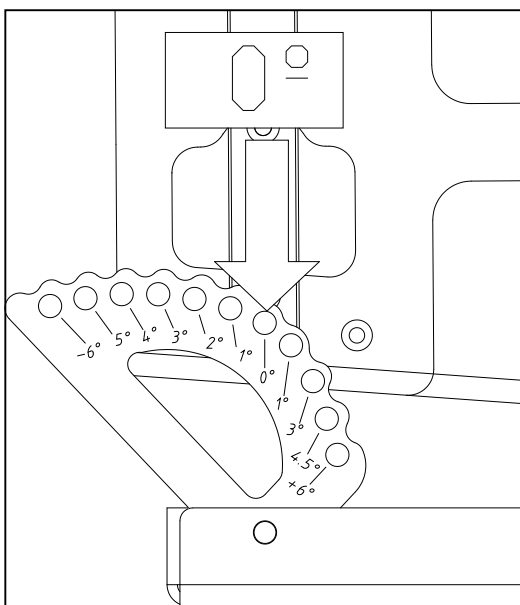

Concave stacking / Rear guide -6°
Stacking cóncavo / Guía trasera -6°

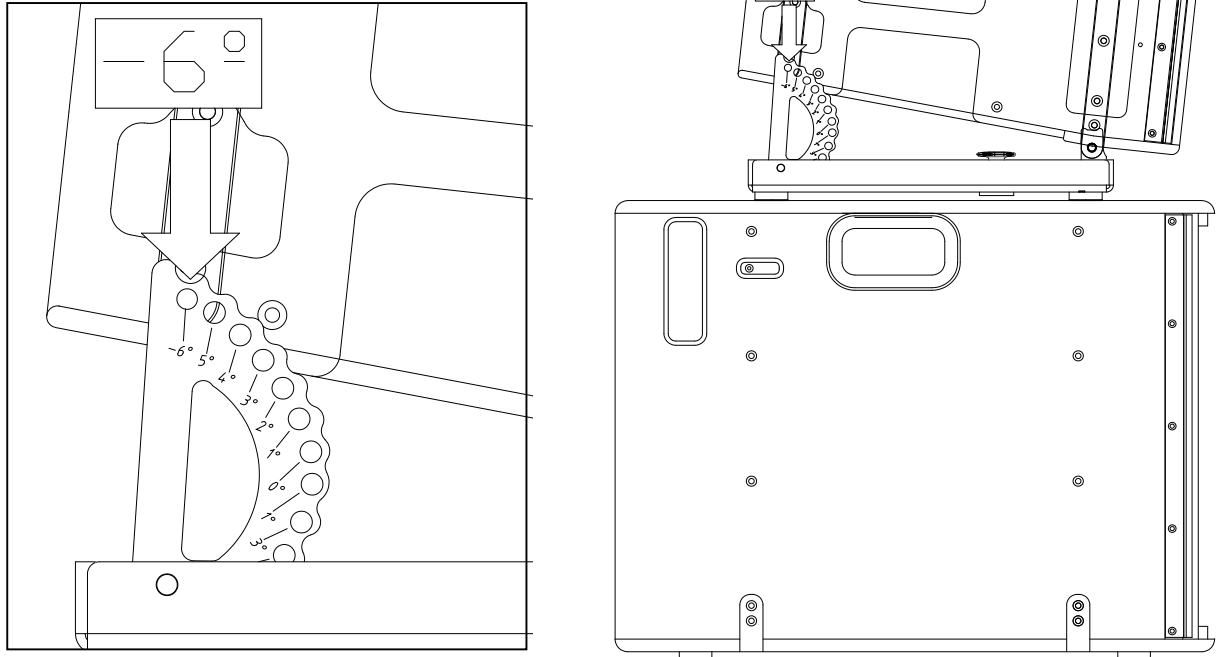

4- Set the other X208 or N208 cabinets over the first unit of X208 or N208 respectively and tilt them as per your requirements.

IMPORTANT NOTE: To avoid any instability we recommend you to stack four X208 or N208 cabinets (maximum) on the subwoofer.

Coloque las siguientes unidades X208 o N208 encima de la primera unidad X208 o N208 respectivamente y graduar según las necesidades.

NOTA IMPORTANTE: *Se recomienda apilar como máximo cuatro cajas X208 o N208 encima del subwoofer. De esta manera se evitan posibles desestabilizaciones debidas a la altura que alcanza el sistema completo.*

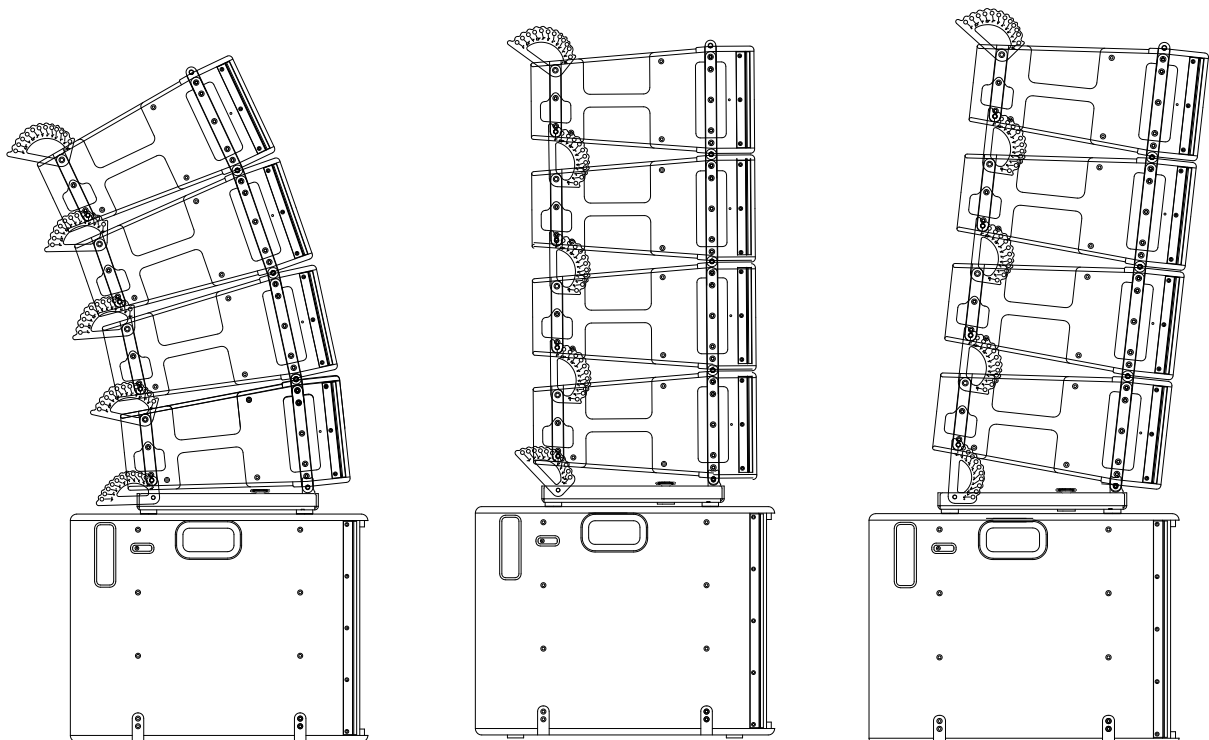

Stacking over X218WF, X218W3K, X218D, X21T, X21D, N218W, N218WP subwoofers

Stacking sobre subwoofers X218WF, X218W3K, X218D, X21T, X21D, N218W, N218WP

- 1- Place the FR-208R stacking frame on the X218WF, X218W3K, X218D, X21T, X21D, N218W or N218WP subwoofer. The lateral bars must face upwards. The FR-208R M10 knob (A) must match the M10 thread (B) on X218WF, X218W3K, X218D, X21T, X21D, N218W, N218WP top socket. Block all the structure using the FR-208R M10 knob (A).

Colocar la estructura de stacking FR-208R encima del subwoofer X218WF, X218W3K, X218D, X21T, X21D, N218W o N218WP. Las barras laterales deben estar mirando hacia arriba. El pomo de M10 del FR-208R (A) debe coincidir con la rosca de M10 de la base del X218WF, X218W3K, X218D, X21T, X21D, N218W o N218WP (B). Asegure toda la estructura bloqueando el pomo de M10 del FR-208R (A).

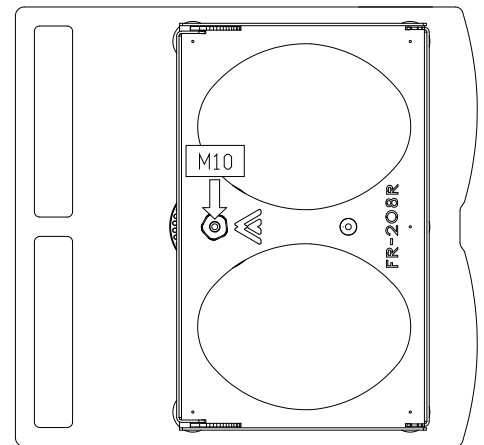
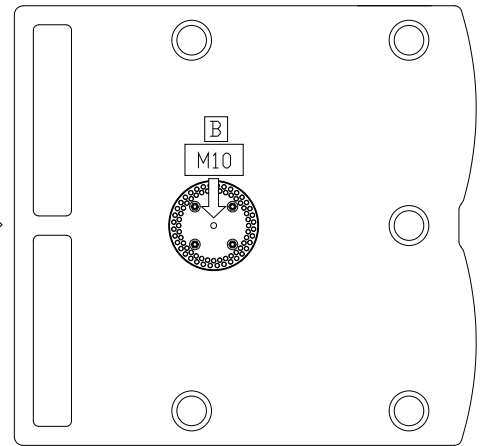
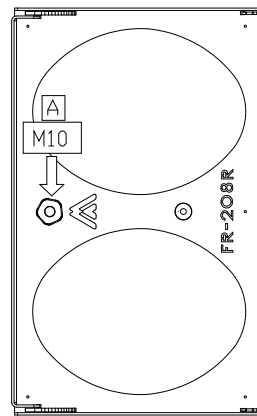
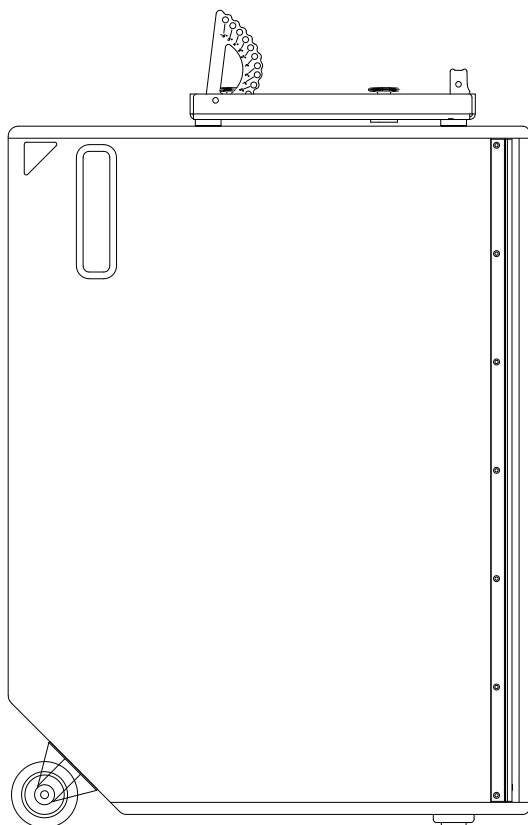

X218W3K / X218D / N218W / N218WP

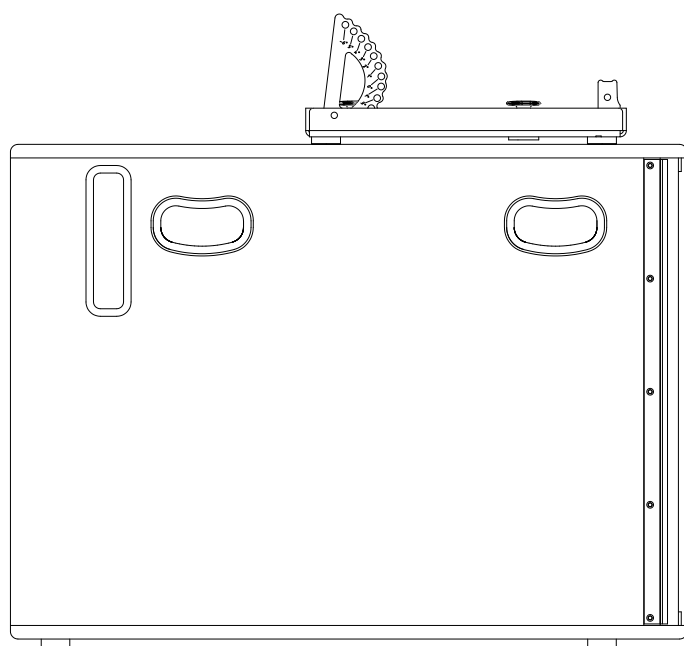
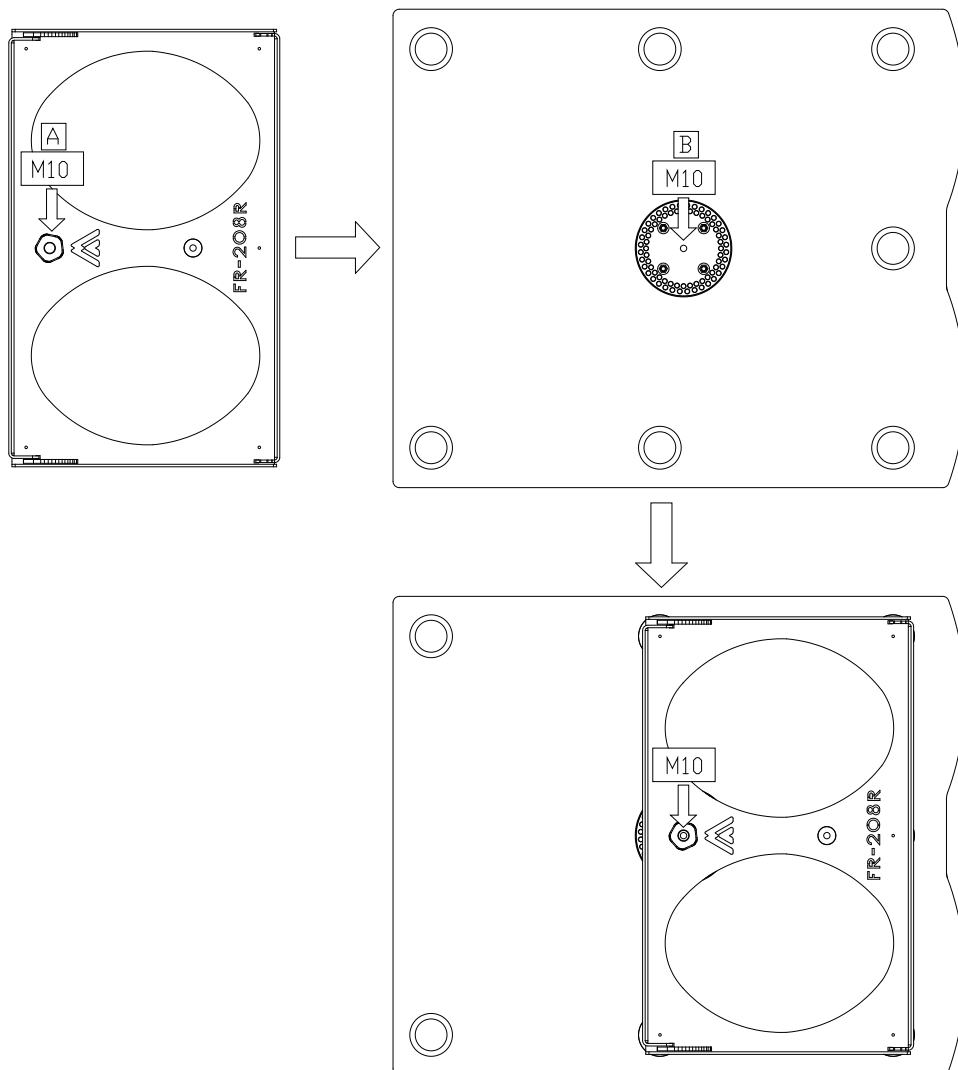

X21T / X21D

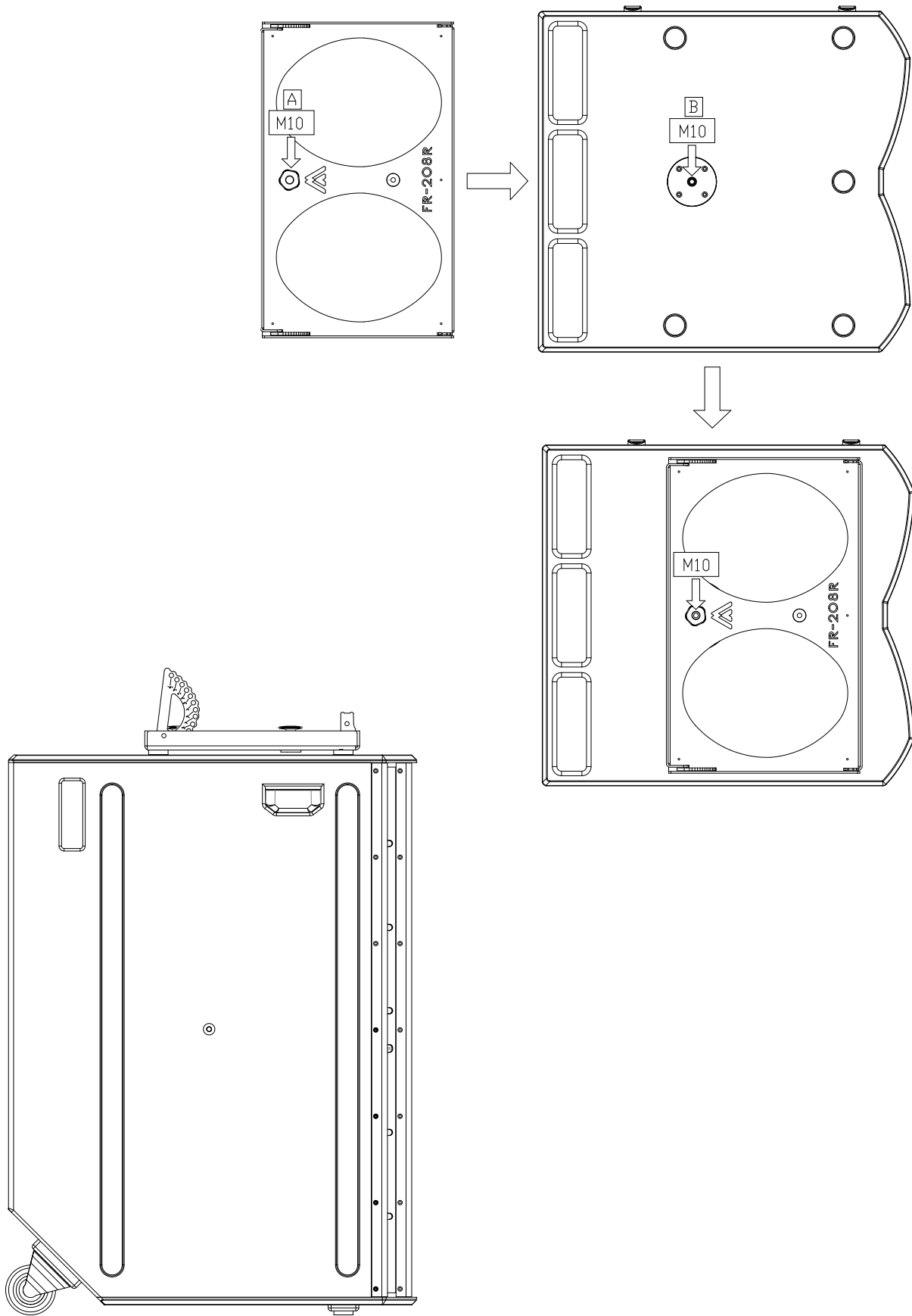

X218WF

- 2- Set the first X208 or N208 cabinet on the FR-208R stacking frame. Use the rear guides to tilt the cabinet. The cabinet can be tilted from 6 degrees (upwards) to 6 degrees (downwards).

Colocar la primera caja X208 o N208 encima de la estructura de stacking FR-208R y graduar según las necesidades. La caja puede ser graduada desde 6° (hacia arriba) hasta 6° (hacia abajo).

Convex stacking / Rear guide +6°
Stacking convexo / Guía trasera +6°

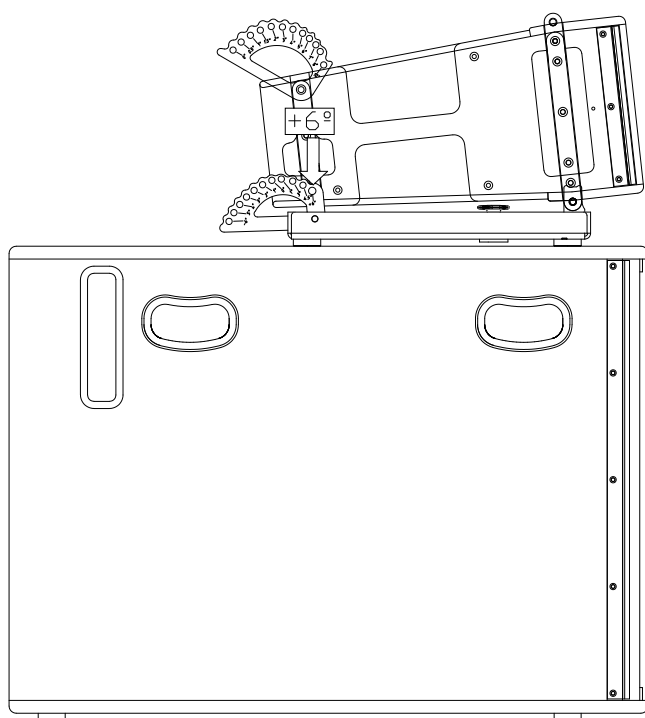
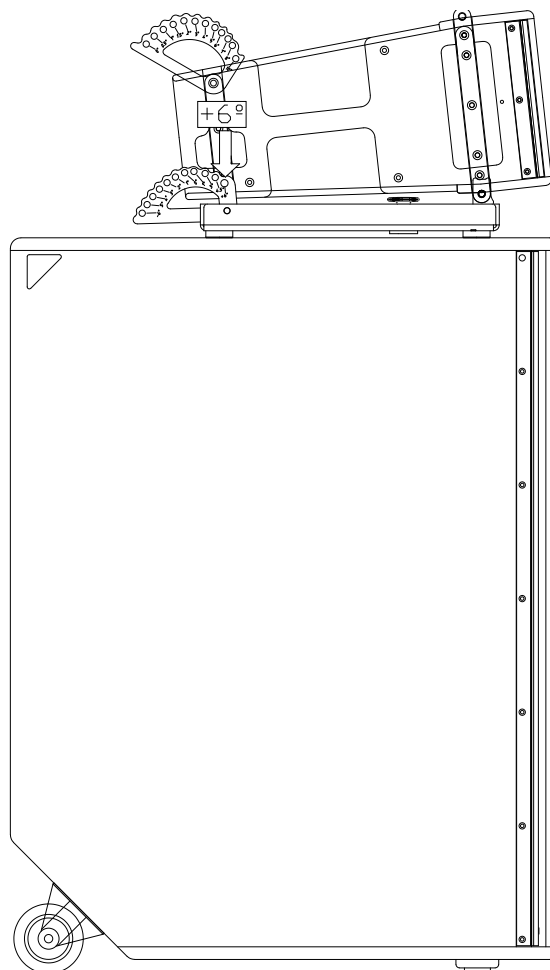
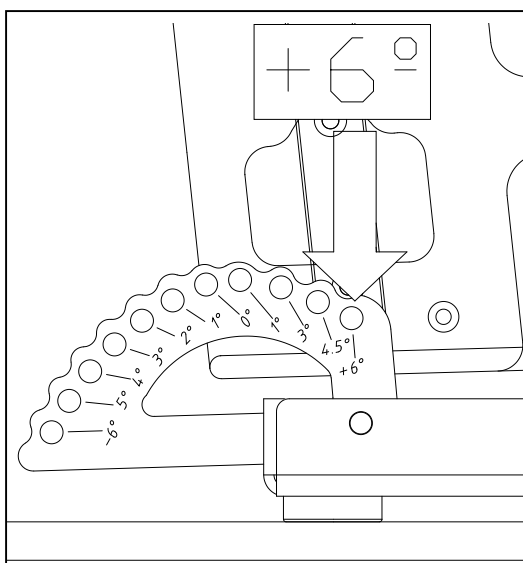

Flat stacking / Rear guide 0°
Stacking plano / Guía trasera 0°

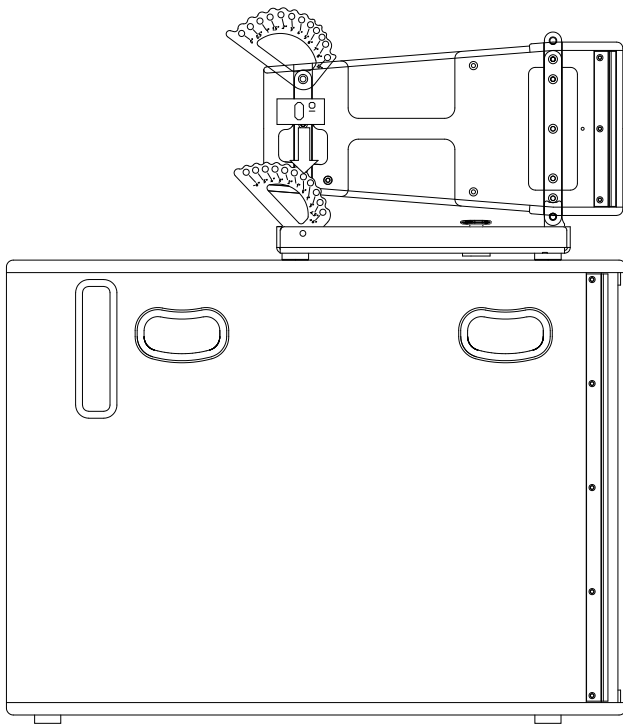
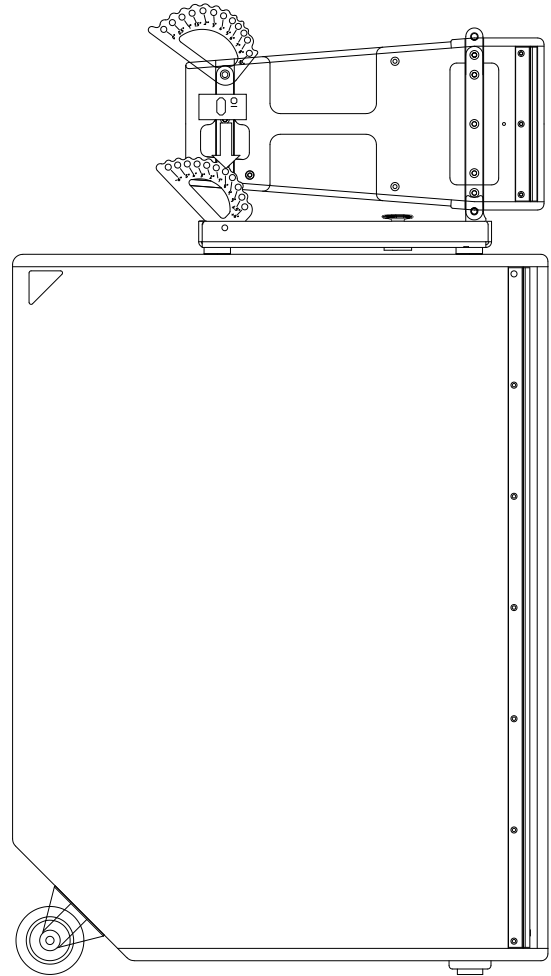
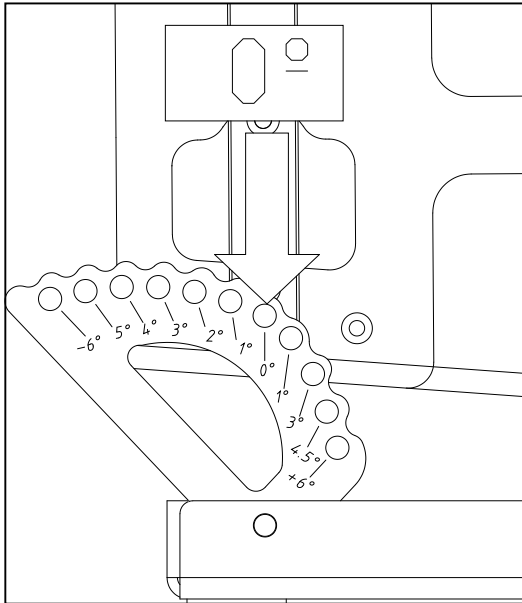

Concave stacking / Rear guide -6°
Stacking cóncavo / Guía trasera -6°

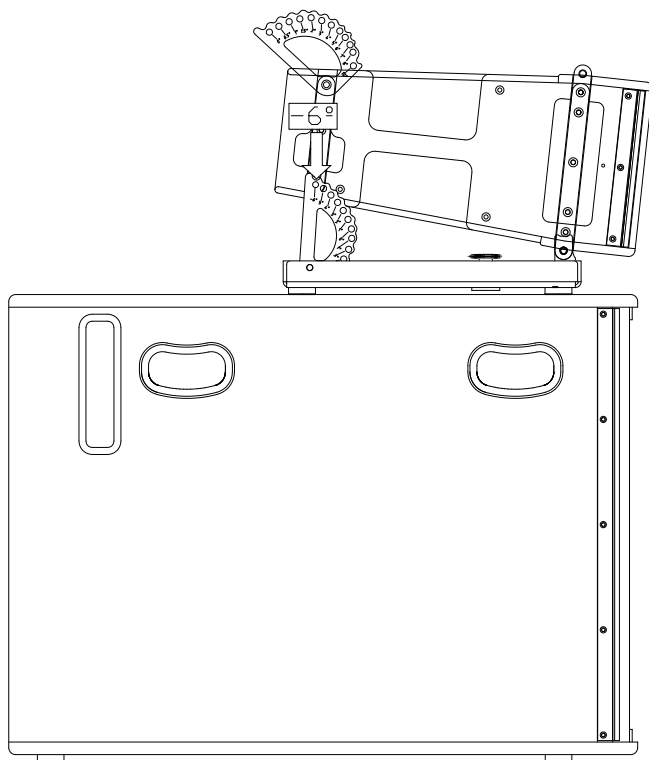
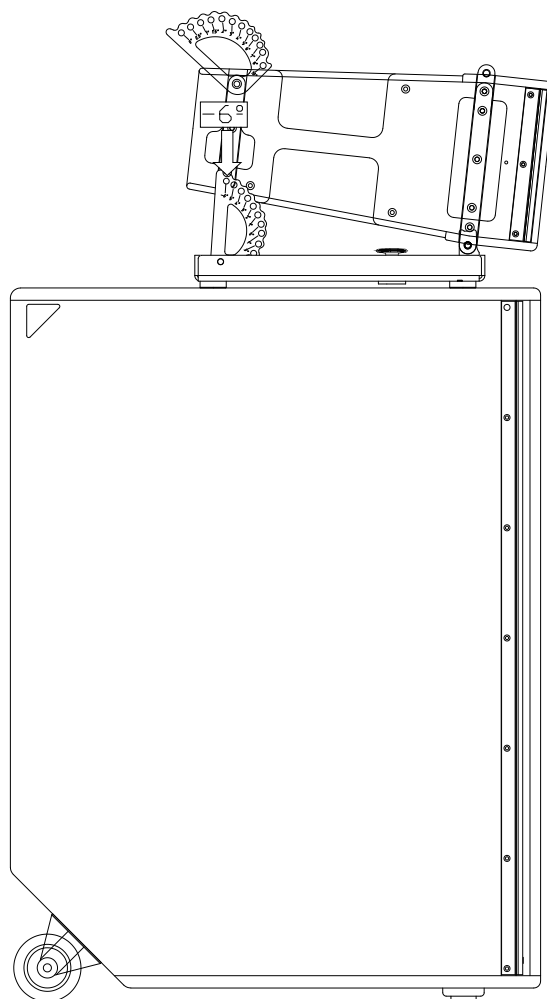
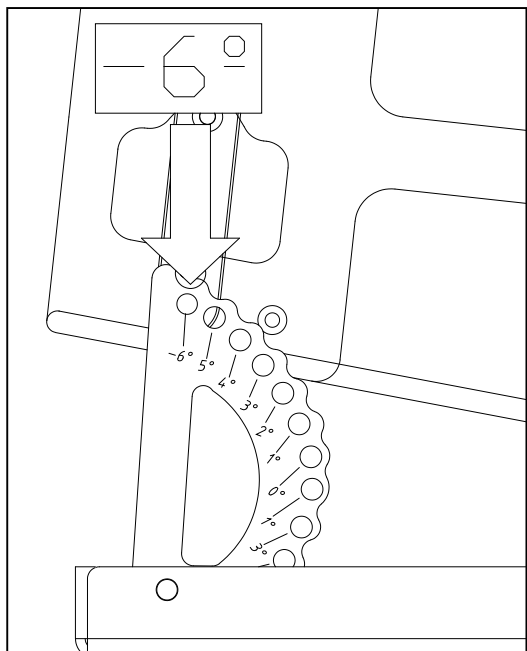

- 3- Set the other X208 or N208 cabinets over the first unit of X208 or N208 respectively and tilt them as per your requirements.

IMPORTANT NOTE: To avoid any instability we recommend you to stack four X208 or N208 cabinets (maximum) on the subwoofer.

Coloque las siguientes unidades X208 o N208 encima de la primera unidad X208 o N208 respectivamente y graduar según las necesidades.

NOTA IMPORTANTE: Se recomienda apilar como máximo cuatro cajas X208 o N208 encima del subwoofer. De esta manera se evitan posibles desestabilizaciones debidas a la altura que alcanza el sistema completo.

